

primus

laundry equipment

Xtreme
in innovation

Industrial Cylinder Heated Drying Ironers

I 80



FEATURES

- Large surface contact with linen
- Finger protection and emergency button for more safety
- Automatic cooldown
- MCX- Easy to operate microprocessor
- Overdimensioned fan for flexible installation
- Indication of ironing speed and temperature
- Reverse mode possible
- Frequency controlled motor
- Space saving installation against the wall is possible: front return
- Electric, gas or steam heating

OPTIONS

- Stop pedal



ROBUST DESIGN



HIGH OUTPUT



LOW ENERGY
CONSUMPTION

TYPE		I 80-320
ROLLER DIAMETER	mm	800
USEFUL ROLLER LENGTH	mm	3200
HEATING		
Electric heating	kW	75
Gas heating*	kW	110
Steam heating	kg/h	190
MOTOR		
Roller motor	kW	0,75
Fan motor	kW	2 x 0,55
Fan capacity	m ³ /h	2 x 1300
IRONING CAPACITY**	kg/h	195
ROLLER SPEED	m/min.	3-15
ELECTRIC CONNECTION		3x380-415V +N 50/60Hz 380-415V (-N) 50/60Hz 440-480V (-N) 50/60Hz 3x220-240V 50/60Hz (not for EI version) 3x440V 50/60Hz 3x380-415V+N 50/60Hz
DIMENSIONS HxWxD	mm	1970x4260x1915
TRANSPORT DATA		
Net weight	kg	2750 - EI, 2600 - G, 2900 - S
Volume (crate packed)	m ³	8,2
Crate packing HxWxD	mm	2100x4350x2000

* G20, 20 mbar
** According to ISO 9398-1

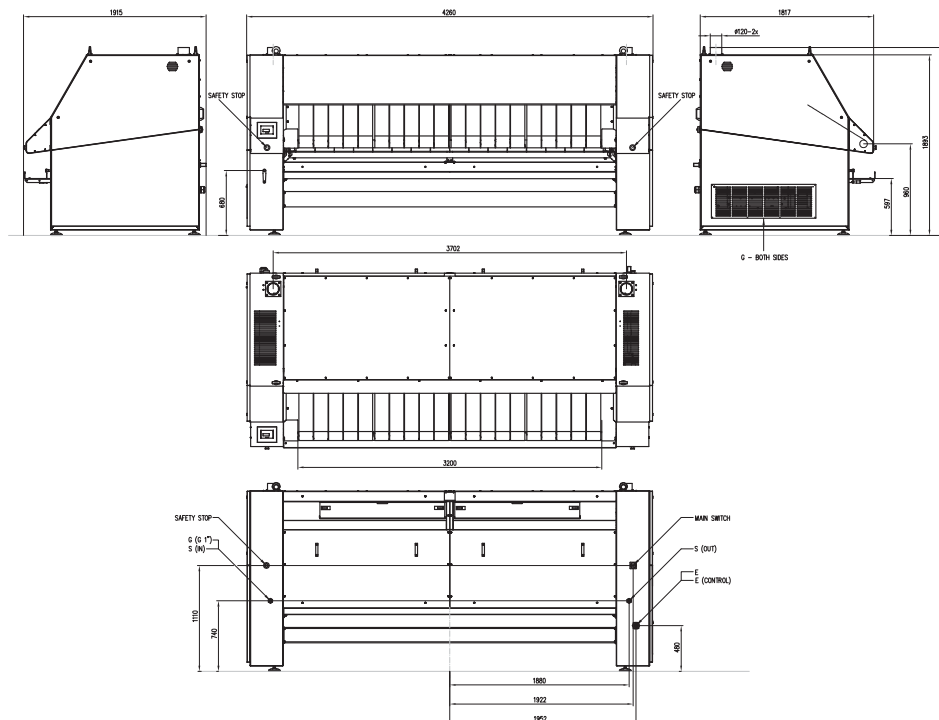

The company Primus preserves the right to change the machines and the specification in this leaflet at any time, without prior notice. Details and photographs are only for information and never binding.

www.primuslaundry.com

ISO 9001
ISO 14001
BUREAU VERITAS
Certification

